



LUNDS
UNIVERSITET

Lecture 8

FRTN10 Multivariable Control

Automatic Control LTH, 2019





Course Outline

- L1–L5 Specifications, models and loop-shaping by hand
- L6–L8 Limitations on achievable performance
 - 6 Controllability/observability, multivariable poles/zeros
 - 7 Fundamental limitations
 - 8 **Multivariable and decentralized control**
- L9–L11 Controller optimization: analytic approach
- L12–L14 Controller optimization: numerical approach
- L15 Course review



L8: Multivariable and decentralized control

- 1 Transfer functions for MIMO systems
- 2 Limitations due to RHP zeros
- 3 Decentralized control
 - Relative gain array (RGA)
 - Decoupling



Typical process control system

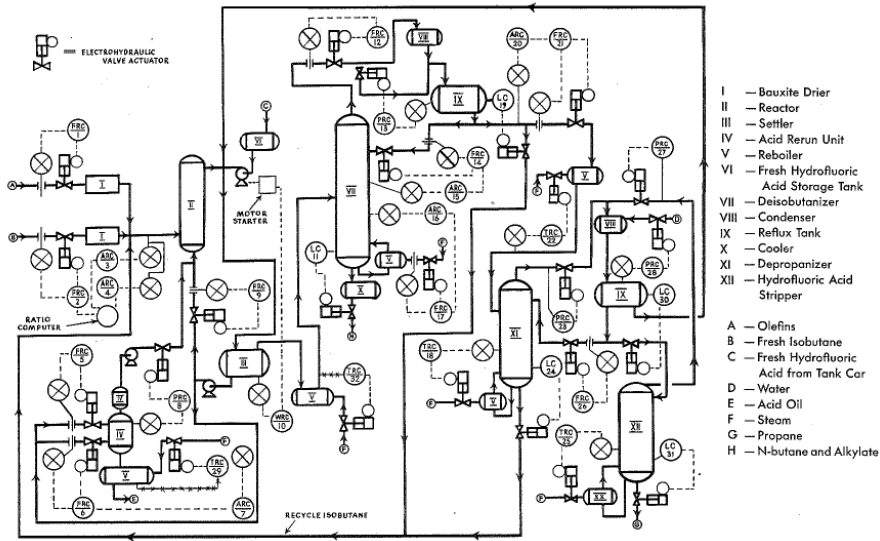
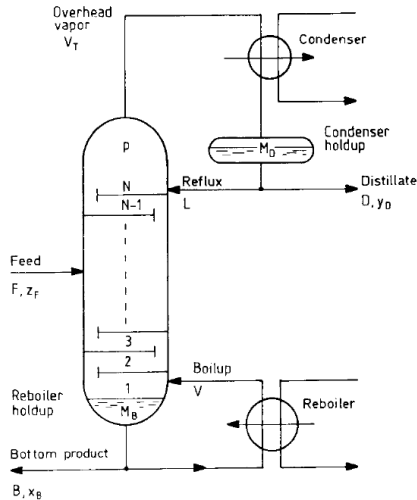

Figure 13-6. Automatic control system for Perco motor fuel alkylation process.



Example system: Distillation column



Raw oil inserted at bottom; different petro-chemical subcomponents extracted



Example system: Distillation column

Outputs:

y_1 = top draw composition

y_2 = side draw composition

Inputs:

u_1 = top draw flowrate

u_2 = side draw flowrate

u_3 = bottom temperature control input

Linear first-order plus deadtime (FOPDT) model:

$$\begin{bmatrix} Y_1(s) \\ Y_2(s) \end{bmatrix} = \underbrace{\begin{bmatrix} \frac{4}{50s+1}e^{-27s} & \frac{1.8}{60s+1}e^{-28s} & \frac{5.9}{50s+1}e^{-27s} \\ \frac{5.4}{50s+1}e^{-18s} & \frac{5.7}{60s+1}e^{-14s} & \frac{6.9}{40s+1}e^{-15s} \end{bmatrix}}_{P(s)} \begin{bmatrix} U_1(s) \\ U_2(s) \\ U_3(s) \end{bmatrix}$$



L8: Multivariable and decentralized control

- 1 Transfer functions for MIMO systems
- 2 Limitations due to RHP zeros
- 3 Decentralized control
 - Relative gain array (RGA)
 - Decoupling



Multivariable transfer functions

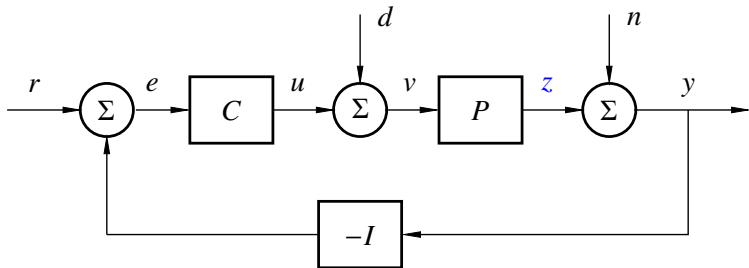

P and C are matrices and all signals are vectors – order matters!

$$Z = PCR + PD - PC(N + Z)$$

$$(I + PC)Z = PCR + PD - PCN$$

$$Z = \underbrace{(I + PC)^{-1} PC}_{G_{zr}=T} R + \underbrace{(I + PC)^{-1} P}_{G_{zd}} D - \underbrace{(I + PC)^{-1} PC}_{G_{zn}} N$$



Multivariable transfer functions

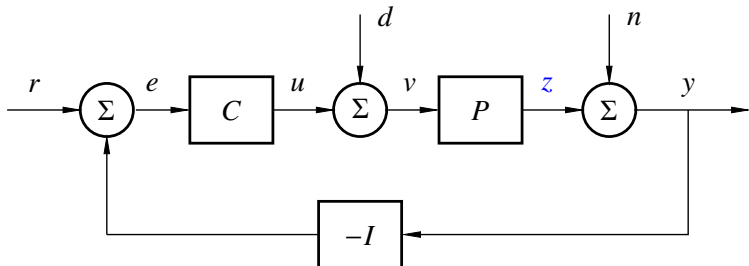

P and C are matrices and all signals are vectors – order matters!

$$\mathbf{Z} = \mathbf{P}\mathbf{C}\mathbf{R} + \mathbf{P}\mathbf{D} - \mathbf{P}\mathbf{C}(\mathbf{N} + \mathbf{Z})$$

$$(\mathbf{I} + \mathbf{P}\mathbf{C})\mathbf{Z} = \mathbf{P}\mathbf{C}\mathbf{R} + \mathbf{P}\mathbf{D} - \mathbf{P}\mathbf{C}\mathbf{N}$$

$$\mathbf{Z} = \underbrace{(\mathbf{I} + \mathbf{P}\mathbf{C})^{-1}\mathbf{P}\mathbf{C}}_{\mathbf{G}_{zr}=\mathbf{T}} \mathbf{R} + \underbrace{(\mathbf{I} + \mathbf{P}\mathbf{C})^{-1}\mathbf{P}}_{\mathbf{G}_{zd}} \mathbf{D} - \underbrace{(\mathbf{I} + \mathbf{P}\mathbf{C})^{-1}\mathbf{P}\mathbf{C}}_{\mathbf{G}_{zn}} \mathbf{N}$$



Sensitivity functions for MIMO systems

Output sensitivity function:

$$(I + PC)^{-1} = S$$

Input sensitivity function:

$$(I + CP)^{-1}$$

Mini-problem:

Find the sensitivity functions above in the block diagram on the previous slide.



Some useful identities

Notice the following identities:

$$(i) [I + PC]^{-1}P = P[I + CP]^{-1}$$

$$(ii) C[I + PC]^{-1} = [I + CP]^{-1}C$$

$$(iii) T = P[I + CP]^{-1}C = PC[I + PC]^{-1} = [I + PC]^{-1}PC$$

$$(iv) S + T = I$$

Proof:

The first equality follows by multiplication on both sides with $[I + PC]$ from the left and with $[I + CP]$ from the right.

$$\text{Left: } [I + PC][I + PC]^{-1}P[I + CP] = I \cdot [P + PCP] = [I + PC]P$$

$$\text{Right: } [I + PC]P[I + CP]^{-1}[I + CP] = [I + PC]P \cdot I = [I + PC]P$$



Some useful identities

Notice the following identities:

$$(i) [I + PC]^{-1}P = P[I + CP]^{-1}$$

$$(ii) C[I + PC]^{-1} = [I + CP]^{-1}C$$

$$(iii) T = P[I + CP]^{-1}C = PC[I + PC]^{-1} = [I + PC]^{-1}PC$$

$$(iv) S + T = I$$

Proof:

The first equality follows by multiplication on both sides with $[I + PC]$ from the left and with $[I + CP]$ from the right.

$$\text{Left: } [I + PC][I + PC]^{-1}P[I + CP] = I \cdot [P + PCP] = [I + PC]P$$

$$\text{Right: } [I + PC]P[I + CP]^{-1}[I + CP] = [I + PC]P \cdot I = [I + PC]P$$



L8: Multivariable and decentralized control

- 1 Transfer functions for MIMO systems
- 2 Limitations due to RHP zeros
- 3 Decentralized control
 - Relative gain array (RGA)
 - Decoupling



Hard limitations from RHP transmission zeros

THEOREM:

Assume that the MIMO system $P(s)$ has a transmission zero z in the RHP.

Let $S(s) = [I + P(s)C(s)]^{-1}$ and let $W_s(s)$ be a scalar, stable and minimum phase transfer function. Then the specification

$$\|W_s S\|_\infty = \sup_{\omega} \overline{\sigma}(W_s(i\omega)S(i\omega)) \leq 1$$

is possible to meet **only if**

$$|W_s(z)| \leq 1$$



Example: Control of MIMO system with RHP zero

Recall the following process from Lecture 6:

$$P(s) = \begin{bmatrix} \frac{2}{s+1} & \frac{3}{s+2} \\ \frac{1}{s+1} & \frac{1}{s+1} \end{bmatrix}$$

Computing the determinant

$$\det P(s) = \frac{2}{(s+1)^2} - \frac{3}{(s+2)(s+1)} = \frac{-s+1}{(s+1)^2(s+2)}$$

shows that the process has a RHP zero in 1, which will limit the achievable performance.

[See lecture notes for details of the following slides]



Example – Controller 1

The controller

$$C_1(s) = \begin{bmatrix} \frac{K_1(s+1)}{s} & -\frac{3K_2(s+0.5)}{s(s+2)} \\ -\frac{K_1(s+1)}{s} & \frac{2K_2(s+0.5)}{s(s+1)} \end{bmatrix}$$

gives the diagonal loop transfer matrix

$$P(s)C_1(s) = \begin{bmatrix} \frac{K_1(-s+1)}{s(s+2)} & 0 \\ 0 & \frac{K_2(s+0.5)(-s+1)}{s(s+1)(s+2)} \end{bmatrix}$$

The system is decoupled into two scalar loops, each with an unstable zero at $s = 1$ that limits the bandwidth.

Closed-loop step responses from (r_1, r_2) to (y_1, y_2) for $K_1 = K_2 = 1$ are shown on next slide.



Step responses using Controller 1

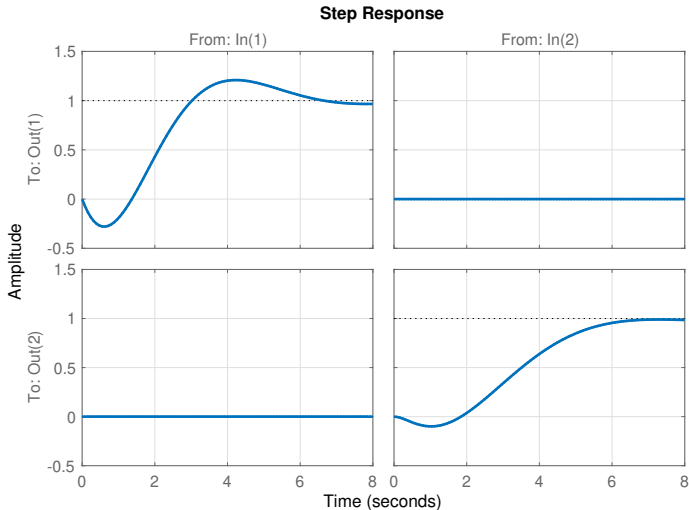

No cross-coupling, but RHP zero shows up in both y_1 and y_2 .



Sensitivity sigma plot using Controller 1

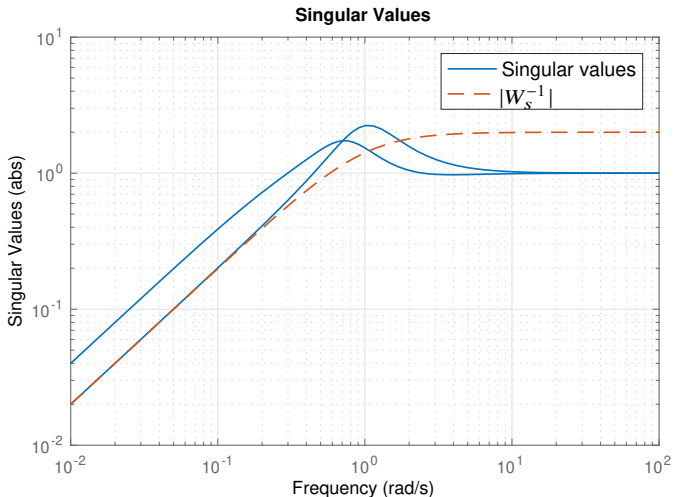

$$W_s(s) = \frac{s+1.01}{2s}, \text{ impossible to meet due to RHP zero}$$



Example – Controller 2

The controller

$$C_2(s) = \begin{bmatrix} \frac{K_1(s+1)}{s} & K_2 \\ -\frac{K_1(s+1)}{s} & K_2 \end{bmatrix}$$

gives the triangular loop transfer matrix

$$P(s)C_2(s) = \begin{bmatrix} \frac{K_1(-s+1)}{s(s+2)} & \frac{K_2(5s+7)}{(s+2)(s+1)} \\ 0 & \frac{2K_2}{s+1} \end{bmatrix}$$

Now the decoupling is only partial: Output y_2 is not affected by r_1 . Moreover, no RHP zero limits the rate of response in y_2 !

The closed-loop step responses for $K_1 = 1$, $K_2 = 10$ are shown on next slide.



Step responses using Controller 2

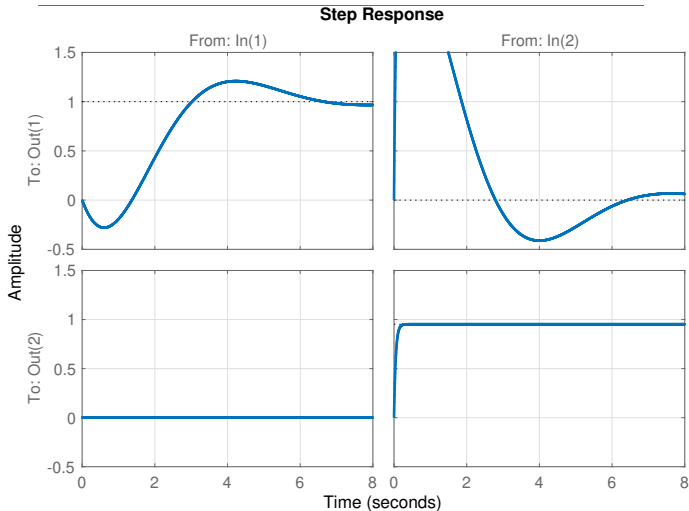

The RHP zero does not prevent a fast y_2 response to r_2 but at the price of a simultaneous undesired response in y_1 .



Sensitivity sigma plot using Controller 2

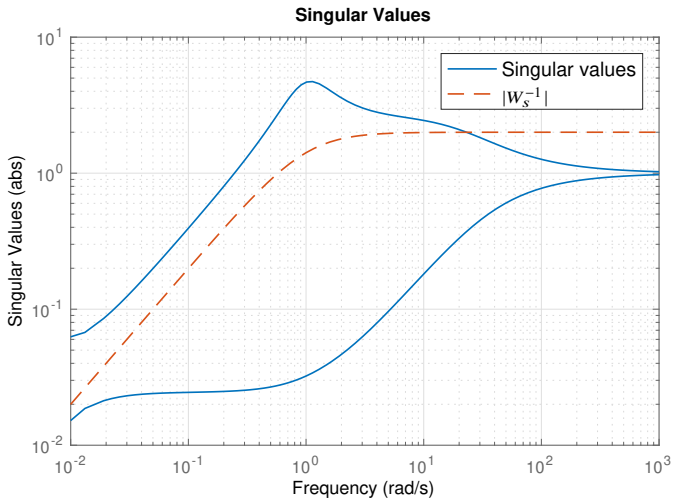

$$W_s(s) = \frac{s+1.01}{2s}, \text{ impossible to meet due to RHP zero}$$



Example – Controller 3

The controller

$$C_3(s) = \begin{bmatrix} K_1 & \frac{-3K_2(s+0.5)}{s(s+2)} \\ K_1 & \frac{2K_2(s+0.5)}{s(s+1)} \end{bmatrix}$$

gives the triangular loop transfer matrix

$$P(s)C_3(s) = \begin{bmatrix} \frac{K_1(5s+7)}{(s+1)(s+2)} & 0 \\ \frac{2K_1}{s+1} & \frac{K_2(-1+s)(s+0.5)}{s(s+1)^2(s+2)} \end{bmatrix}$$

In this case y_1 is decoupled from r_2 and can respond arbitrarily fast for high values of K_1 , at the expense of bad behavior in y_2 . Step responses for $K_1 = 10$, $K_2 = 1$ are shown on next slide.



Step responses using Controller 3

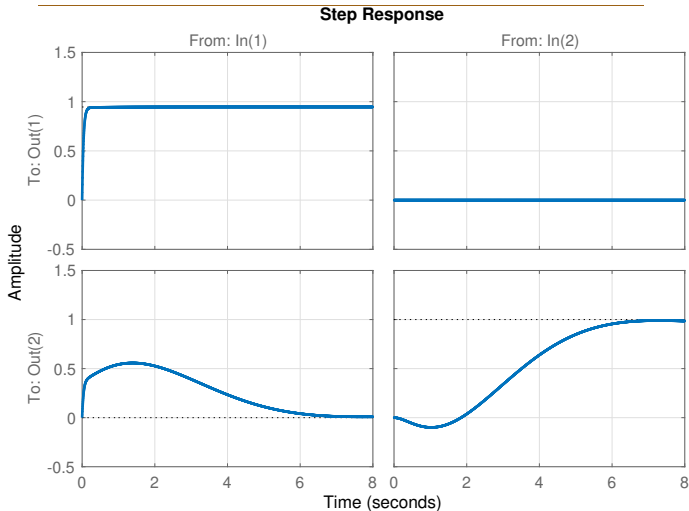

The RHP zero does not prevent a fast y_1 response to r_1 but at the price of a simultaneous undesired response in y_2 .



Sensitivity sigma plot using Controller 3

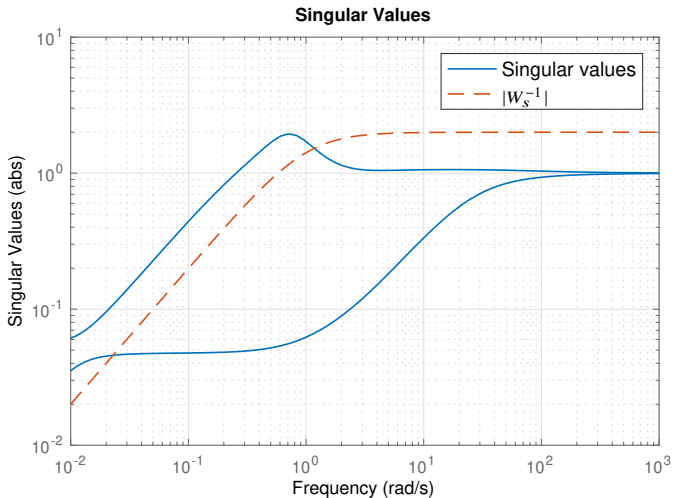

$$W_s(s) = \frac{s+1.01}{2s}, \text{ impossible to meet due to RHP zero}$$



Example – summary

To summarize, the example shows that even though a **multivariable RHP zero always gives a performance limitation**, it is possible to influence where the effects should show up.



L8: Multivariable and decentralized control

- 1 Transfer functions for MIMO systems
- 2 Limitations due to RHP zeros
- 3 Decentralized control
 - Relative gain array (RGA)
 - Decoupling



Decentralized control

Background in process control:

- A few important variables were controlled using the simple loop paradigm: one sensor, one actuator, one controller
- As more loops were added, interaction was handled using feedforward, cascade and midrange control, selectors, etc.
- Not always obvious how to associate sensors and actuators – the pairing problem

Computer control and state-space design methods eventually led to centralized MIMO control schemes (LQG, MPC, etc.)



Interaction between simple loops

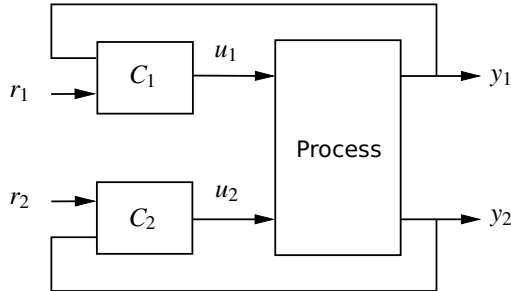

$$Y_1(s) = P_{11}(s)U_1(s) + P_{12}U_2(s)$$

$$Y_2(s) = P_{21}(s)U_1(s) + P_{22}U_2(s),$$

What happens when the controllers are tuned individually (C_1 for P_{11} and C_2 for P_{22}), ignoring the cross-couplings (P_{12} and P_{21})?



Rosenbrock's example

$$P(s) = \begin{pmatrix} \frac{1}{(s+1)^2} & \frac{2}{(s+1)^2} \\ \frac{1}{(s+1)^2} & \frac{1}{(s+1)^2} \end{pmatrix}$$

Very benign subsystems, no fundamental limitations.



Rosenbrock's example with two SISO controllers

- $U_1 = \left(1 + \frac{1}{s}\right)(R_1 - Y_1)$
- $U_2 = -K_2 Y_2$ with $K_2 = 0, 0.8,$ and $1.6.$

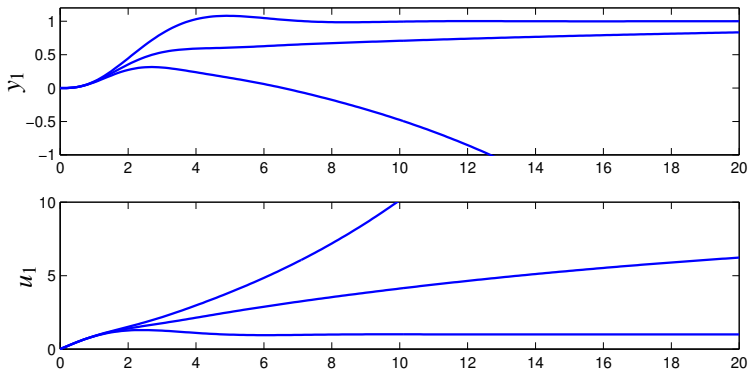

The second controller has a major impact on the first loop! Gain reversal in $u_1 \rightarrow y_1$ when $K_2 = 1.6$.



Relative Gain Array (RGA)

- Edgar H. Bristol, "On a new measure of interaction for multivariable process control" [**IEEE TAC** 11(1967) pp. 133–135]
- A simple way of measuring interaction in MIMO systems
- Idea: Study how the gain between one input and one output changes when all other outputs are regulated:

$$\text{relative gain} = \frac{\text{open-loop gain}}{\text{"closed-loop gain"}}$$

- Often only the static gain $P(0)$ is analyzed, but one could also look at for instance $P(i\omega_c)$ and other frequencies



Calculation of RGA

Assume the input-output relation $y = Gu$, where G is square and invertible.

Open loop: Assume $u_j \neq 0$ and all other inputs zero. Then

$$y_k = G_{kj}u_j$$

Closed loop: Assume $y_k \neq 0$ and that all other outputs are regulated to zero. Solving for the corresponding inputs gives

$$u_j = G_{jk}^{-1}y_k \quad \Leftrightarrow \quad y_k = \frac{1}{G_{jk}^{-1}}u_j$$



Calculation of RGA

Relative gain:

$$\lambda_{kj} = G_{kj} \cdot G_{jk}^{-1}$$

All elements of the relative gain array (matrix) can be computed in one go as

$$\Lambda = \text{RGA}(G) = G .* (G^{-1})^T$$

where `.*` denotes element-wise (Hadamard/Schur) multiplication

Matlab: `RGA = G.*inv(G).'`



Properties of RGA

- RGA is dimensionless; not affected by choice of units or scaling.
- RGA is normalized: Rows and columns of Λ sum to 1 (for square systems)
- Diagonal or triangular plant gives $\Lambda = I$.



Interpretation of RGA

- $\lambda_{kj} \approx 1$ means small closed-loop interaction. Suitable to pair output k with input j .
- $\lambda_{kj} < 0$ corresponds to a sign reversal due to feedback and a risk of instability if output k is paired with input j – avoid!
- $0 < \lambda_{kj} < 1$ means that the closed-loop gain is larger than the open-loop gain; the opposite is true for $\lambda_{kj} > 1$.

Rule of thumb: Pair the outputs and inputs so that corresponding relative gains are positive and as close to 1 as possible (in absolute distance sense)



Interpretation of RGA

- $\lambda_{kj} \approx 1$ means small closed-loop interaction. Suitable to pair output k with input j .
- $\lambda_{kj} < 0$ corresponds to a sign reversal due to feedback and a risk of instability if output k is paired with input j – avoid!
- $0 < \lambda_{kj} < 1$ means that the closed-loop gain is larger than the open-loop gain; the opposite is true for $\lambda_{kj} > 1$.

Rule of thumb: Pair the outputs and inputs so that corresponding relative gains are positive and as close to 1 as possible (in absolute distance sense)



RGA of Rosenbrock's example

Analysis of static gain:

$$P(0) = \begin{pmatrix} 1 & 2 \\ 1 & 1 \end{pmatrix}, \quad P^{-1}(0) = \begin{pmatrix} -1 & 2 \\ 1 & -1 \end{pmatrix}$$

$$\Lambda = P(0) .* (P^{-1}(0))^T = \begin{pmatrix} -1 & 2 \\ 2 & -1 \end{pmatrix}$$

- Negative value of λ_{11} indicates the problematic sign reversal found previously when y_1 was controlled using u_1 .
- Better to use reverse pairing, i.e. let u_2 control y_1 and vice versa.



Rosenbrock's example with reverse pairing

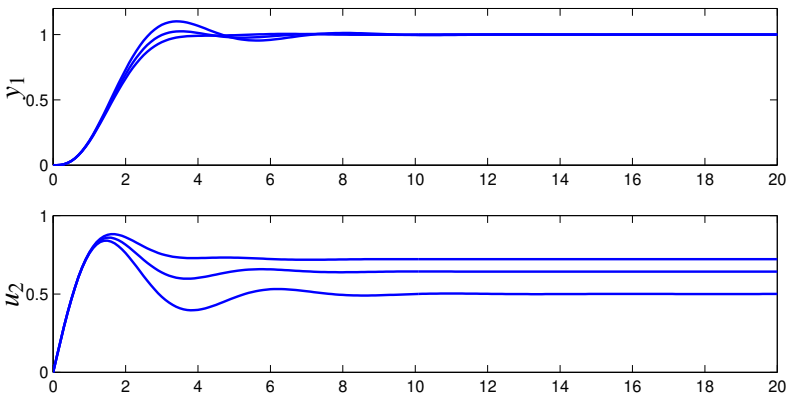

- $U_2 = \left(1 + \frac{1}{s}\right)(R_1 - Y_1)$
- $U_1 = -K_2 Y_2$ with $K_2 = 0, 0.8,$ and 1.6 .



RGA of non-square systems

The RGA can also be computed for a general gain matrix G :

$$\text{RGA}(G) = G .* (G^\dagger)^T$$

Here, \dagger denotes the pseudo-inverse (Matlab: pinv)

Example: Distillation column:

$$P(0) = \begin{pmatrix} 4.0 & 1.8 & 5.9 \\ 5.4 & 5.7 & 6.9 \end{pmatrix}, \quad \text{RGA}(P(0)) = \begin{pmatrix} 0.28 & -0.61 & 1.33 \\ 0.01 & 1.58 & -0.59 \end{pmatrix}$$

Suggested pairing for decentralized control: $y_1 \rightarrow u_3$, $y_2 \rightarrow u_2$, u_1 unused



RGA of non-square systems

The RGA can also be computed for a general gain matrix G :

$$\text{RGA}(G) = G .* (G^\dagger)^T$$

Here, \dagger denotes the pseudo-inverse (Matlab: pinv)

Example: Distillation column:

$$P(0) = \begin{pmatrix} 4.0 & 1.8 & 5.9 \\ 5.4 & 5.7 & 6.9 \end{pmatrix}, \quad \text{RGA}(P(0)) = \begin{pmatrix} 0.28 & -0.61 & 1.33 \\ 0.01 & 1.58 & -0.59 \end{pmatrix}$$

Suggested pairing for decentralized control: y_1-u_3 , y_2-u_2 , u_1 unused



Decoupling

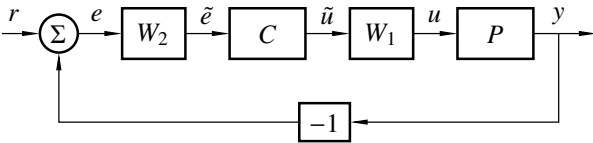

Idea: Select decoupling filters W_1 and W_2 so that the controller sees a diagonal plant:

$$\tilde{P} = W_2 P W_1 = \begin{bmatrix} * & 0 & 0 \\ 0 & * & 0 \\ 0 & 0 & * \end{bmatrix}$$

Then we can use a decentralized controller C with the same diagonal structure.



Decoupling

Many variants/names:

- Input/conventional/feedforward decoupling: $\tilde{P} = PW_1$, $W_2 = I$
- Output/inverse/feedback decoupling: $\tilde{P} = W_2P$, $W_1 = I$

W_1 and W_2 can be static or dynamic systems

Example: Static input decoupling: $W_1 = P^{-1}(0)$, $W_2 = I$



Lab 2: The quadruple tank

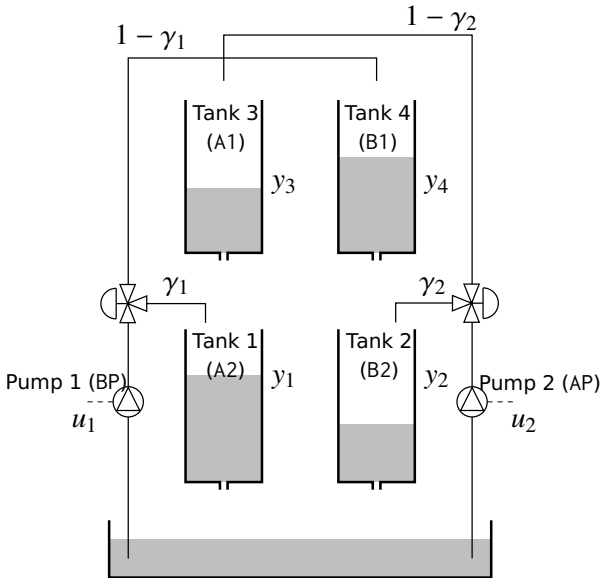



Lecture 8 – summary

- MIMO transfer functions – be careful
- Multivariable RHP zeros \Rightarrow limitations similar to SISO case
 - Don't forget process redesign
- All real MIMO systems are coupled to some degree
- Decentralized control – one controller per controlled variable
 - RGA gives insight for input–output pairing
- Decoupling
 - The controller sees a simpler, (near-)diagonal system
 - SISO design, tuning and operation can be used for each loop